

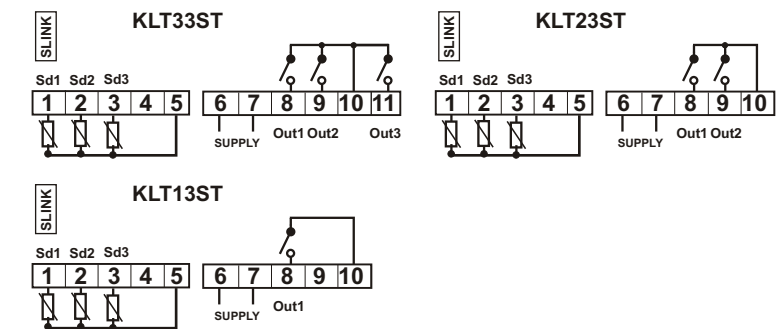

Wiring Diagram



Description

KLT13ST, KLT23ST, and KLT33ST controls are designed for most thermal solar energy applications, with inlets for PTC-type temperature probes and a 3-digit temperature display. They have a solar collector probe (sd1), water storage tank top probe (sd2), and water storage tank bottom probe (selectable, sd3). Allows control of the solar collector pump (out1), auxiliary heating (out2), and surplus energy use function (out3).

Users may program 21 different parameters, including maximum water storage tank temperature and solar collector temperature deltas.

The control includes error warning and protection password. The choices are red, green, or blue display; temperature in °C or °F; and 230Vac, 115Vac, 24Vac/dc, or 12Vac/dc power supply.

Model references

The model reference is given by: KLTX3ST-PVYZ

Where each suffix can take the following values:

V	Display Color	R=Red, G=Green, B=Blue
Y	Supply Voltage	230=230Vac, 115=115Vac 24=24Vac/dc, 12=12Vac/dc
Z	Units	C=°C, F=°F

Installation

The thermostat must be located in a place protected from vibrations, impacts, water and corrosive gases.

It will be made a 71x29mm panel cut-out to insert the thermostat (apply silicone to make it leaktight). Then the fixing clips must be fasten, sliding it onto the thermostat, until it is well secure.

Wiring

Avoid installing the cables of the probes and the digital input, in the proximity of any power cable.

Maintenance, cleaning and repair

After final installation of the unit, no routine maintenance is required.

Clean the surface of the display controller with a soft and damp cloth. Never use abrasive detergents, petrol, alcohol or solvents.

All repairs must be made by authorised personnel.

Technical Data

Supply voltages

115Vac±10%, 230Vac±10%, 24Vac/dc±10%, 12Vac/dc±10%

Supply powers

4VA (230V/115V) 1,5VA(24V /12V)

Storage temperature

-20°C to 80°C (-4 to 176°F)

Operating temperature

0°C to 70°C (32 to 158°F)

Probe range

PTC -50°C to 150°C (-58 to 302°F)

Accuracy

Better than 1% of full scale

Resolution

1° (3 digits)

Display

3-digit and sign

Probes

PTC1000 probes (25°C - 1000 Ohm)

sd1: solar collector probe.

Sd2: water storage tank bottom probe

Sd3: water storage tank top probe (selectable by parameter).

Outputs

Out1, solar collector circulation pump:

SPST Relay Resistive load 5A 240Vac

Out2, auxiliary heating (KLT23ST-PX and KLT33ST-PX):

SPST Relay Resistive load 16A 240Vac

1HP 240Vac -- 10FLA, 60LRA 240Vac

Out3, surplus energy use (KLT33ST-PX):

SPST Relay Resistive load 8A 240Vac

Dimensions

Front 77 x 36 mm Depth 62 mm (3.03 x 1.42 x 2.44 inch)

Front Protection

IP64

Parameter programming

Maximum water storage tank temperature (tSt) is the only parameter the user can access without code protection.

- Press SET. tSt *text will appear on the display.*
- Press SET again. The real value is shown on the display.
- The value can be modified with the UP and DOWN arrows.
- Press SET to enter any new values.
- Press SET and DOWN at the same time to quit programming or wait one minute and the display will automatically exit programming mode.

Access to all code protected parameters.

- Press SET for 8 seconds. The access code value 0 is shown on the display (unit comes with code set at 0 from factory).
- With the UP and DOWN arrows, code can be set to user needs.
- Press SET to enter the code. If code correct, the first parameter label is shown on the display (tSt).
- Move to the desired parameter with the UP and DOWN keys.
- Press SET to view the value on the display.
- The value can be modified with the UP and DOWN keys.
- Press SET to enter the value and exit.
- Repeat until all necessary parameters are modified.
- Press SET and DOWN at the same time to quit programming or wait one minute and the display will automatically exit programming mode.

**The keyboard code can be reset to ZERO by turning off the controller and turning it on again while keeping the SET pressed.*

To record a standard configuration

- Access to parameter H0 as explained in Parameter programming.
- Choose desired configuration.
- For series KLT13ST-Px: H0 = 0
- For series KLT23ST-Px: H0 = 1
- For series KLT33ST-Px: H0 = 2
- Press SET for 8 seconds, and the thermostat will be reset.
- Press SET + DOWN to quit or wait for 1 minute (keyboard timeout).

Led Indications

- ▶ Indicates circulation pump on (Out1).
- Ⓜ Indicates auxiliary heating demand on (Out2).
- Ⓜ Indicates water storage tank surplus energy use on (Out3).
- ▶ Ⓜ Ⓜ 90% on 10% off flicker if forced to on, 10% on 90% off flicker if forced to off (Hn1, Hn2, Hn3 parameters).
- ☼ Indicates that the sd2 water storage tank temperature has reached the tSt maximum temperature set. 90% on 10% off flicker indicates solar collector cooling. 10% on 90% off flicker indicates water storage tank cooling.
- ☼ Indicates active anti-freeze. 10% on 90% off flicker indicates active limitation due to low solar collector temperature.

Display Messages

In normal operation the probe temperature selected by vSd will be displayed. In error case, the following messages can also appear:
Err: Memory reading error..
EP1: Probe 1 error, when vSd other than 1.
EP2: Probe 2 error, when vSd other than 2.
EP3: Probe 3 error, when vSd other than 3.
CoH: Active maximum collector temperature limitation
ooo : Open probe, the selected by vSd parameter.
----: Short-circuited probe, the selected by vSd parameter.

By clicking on SET+UP at the same time, we switch from main probe view to a view of the probes NOT chosen by the vSd parameter. The viewed probe then switches its value from the SD1, SD2, or SD3 message, indicating the corresponding probe.

SLINK

In this input we can connect a programming key to read or to write the parameters.

If we manage the system with a PC we can connect it to the thermostat through this input with a communication module.

Operation in Error Case

All relays are off when there is memory error (Err).

Solar collector probe sd1 error: Powers off the solar circuit’s circulation pump. Does not affect all other relays.

Water storage tank bottom probe sd2 error: Powers off the solar circuit’s circulation pump. When not using sd3 (top probe), it powers off the auxiliary heating and the surplus energy use function.

Water storage tank top probe sd3 error: Does not affect the solar circuit’s circulation pump. Powers off the auxiliary heating and the surplus energy use function.

Differential thermostat operation

From the following example, dto = 6°C, dtF = 4°C, tSt = 60°C.

The circulation pump is on when sd2 has not reached the tSt parameter and there is also a temperature differential between sd1 and sd2 higher than the dto on delta parameter. When for example sd2 = 50°C, the circulation pump is on when sd1 > (50 + 6 = 56°C). When sd2 is above 60°C (tSt), the circulation pump is not powered on.

Once started, the circulation pump will be powered off when the temperature differential between sd1 and sd2 is below the dtF off delta parameter. For example, keeping sd2 = 50°C, the circulation pump is powered off when Sd1 drops from 50 + 4 = 54°C. The circulation pump will also be powered off when sd2 exceeds the 60°C tSt parameter in this example.

Auxiliary heating operation

The auxiliary heating function is implemented in KLT23ST-PX and KLT33ST-PX, and NOT in KLT13ST-PX.

The auxiliary heating demand (from a boiler, electric resistance, etc.) is used to heat up the water storage tank when solar radiation has been insufficient and the water storage tank is at a low temperature.

The oEA parameter must be configured to Yes, after which it is possible to program the water storage tank temperature (tEA parameter) below which the thermostat will trigger the auxiliary heating.

When the thermostat has sd3 (Pb3=Yes), it uses this sd3 to set the auxiliary heating. When no sd3 (Pb3=No) is available, the thermostat uses sd2 to set the auxiliary heating.

For example, oEA=Yes, tEA=45°C, Pb3=Yes.

When sd3 < 45°C, the auxiliary heating is on, and the external power supply system will increase the temperature of the water storage tank. When sd3 > (45°C + 1°K = 46°C), the auxiliary heating is powered off.

Surplus energy use operation

The surplus energy use function is implemented in KLT33ST-PX and NOT in KLT13ST-PX or KLT23ST-PX.

For the thermostat to order the transfer of the surplus energy from the water storage tank to an external system, it is necessary to configure the odl parameter to Yes. Once odl=Yes, it is possible to set the water storage tank temperature (tdl parameter) above that at which the thermostat triggers the surplus energy use function.

When the thermostat has sd3 (Pb3=Yes), it uses it to set the surplus energy use function. When lacking it (Pb3=No), the thermostat uses sd2 to set the surplus energy use function, e.g. odl=Yes, tdl=70°C, Pb3=Yes.

When sd3 > 70°C, the surplus energy use function is triggered, and the external surplus energy use system lowers the temperature of the water storage tank. When sd3 <(70°C - 1°K = 69°C), the surplus energy use function is powered off.

List of parameters

	Description	Units	Range	Factory
tSt	Maximum water storage tank temperature	°C	2 to 95	60
		°F	36 to 203	140
dto	On temperature delta	°C	dtF+1 to 21.0	6.0
		°F	dtF+1 to 37.8	10.8
dtF	Off temperature delta	°C	1.0 to dto-1	4.0
		°F	1.8 to dto-1	7.2
tHc	Collector temperature limit	°C	60 to 150	140
		°F	140 to 302	284
oSc	System cooling option	Option	No/Yes	No
tSc	System cooling temperature	°C	60 to 150	120
		°F	140 to 302	248
ocL	Minimum collector temperature option	Option	No/Yes	No
tcL	Minimum collector temperature	°C	-10 to 90	10
		°F	14 to 194	50
ocF	Anti-freeze option in collector	Option	No/Yes	No
tcF	Anti-freeze temperature in collector	°C	-10 to 10	4
		°F	14 to 50	39
oEA	Auxiliary heating option	Option	No/Yes	No
tEA	Auxiliary heating temperature	°C	0 to 95	45
		°F	32 to 203	113
odl	Surplus energy use option	Option	No/Yes	No
tdl	Surplus energy use temperature	°C	0 to 95	70
		°F	32 to 203	158

Pb3	Sd3 option (top probe)	Option	No/Yes	No
Usd	Probe to display	Numeric	1 to 3	1
Hn1	Manual/automatic circulation pump	Option	On/OFF/Aut	Aut
Hn2	Manual/automatic auxiliary heating	Option	On/OFF/Aut	Aut
Hn3	Manual/automatic surplus energy use	Option	On/OFF/Aut	Aut
H0	Factory Settings	Numeric	0 to 2	0
H5	Access code to parameters	Numeric	0 to 255	0

Parameter description

tSt Maximum water storage tank temperature: Maximum temperature desired for the part below (sd2) the water storage tank. .

When sd2 > tst : circulation pump off.

When sd2 <= tst-1°K : circulation pump on or off depending on sd1.

Note: The control is fitted with sd2 safety at 95°C so that the circulation pump is never powered on when sd2 > 95°C.

dto on temperature delta: Degrees at which sd1 must be above sd2 to power on the circulation pump.

dtF off temperature delta: Degrees at which sd1 must be above sd2 to power off the circulation pump.

tHc Maximum collector temperature limit: When sd1 exceeds the tHc parameter, the circulation pump is powered off to prevent the high temperature from damaging the facility’s components.

When sd1 >tHc : circulation pump off, “**Coh**” message.

When sd1 <= tHc -5°K: Return to normal operation

oSc System cooling option:

No: No system cooling is applied, tSc is not accessed.

Yes: System cooling applied according to temperature tSc.

tSc System cooling temperature:

Solar collector cooling: When sd2 > tSt and tSc<sd1< 95°C, the circulation pump is powered on to cool the collector and power the water storage tank.

The circulation pump is powered off when sd1 < tSc-1°K.

Water storage tank cooling: When sd2 > tSt and sd1<sd2 -5°K, the circulation pump is powered on to cool the water storage tank. The circulation pump is powered off when sd1>sd2 -5°K+1°K.

ocL Minimum collector temperature option:

No: No limitation applied due to minimum collector temperature. The tcL parameter is not accessed.

Yes: Limitation applied due to minimum collector temperature according to the temperature set in the tcL parameter.

tcL Minimum collector temperature: When sd1 < tcL, the circulation pump is not powered on due to temperature delta (limitation due to active low collector temperature), thus preventing unnecessary operations. The low collector temperature limitation is powered off with sd1 > tcL+ 1°K.

ocF Anti-freeze option:

No: No anti-freeze protection applied on the collector, tcF is not accessed.

Yes: Anti-freeze protection applied on collector at temperature tcF.

tcF Anti-freeze temperature on collector: The anti-freeze situation is powered on when sd1 < tcF by powering on the circulation pump and heating up the solar collector. The anti-freeze option is powered off when sd1 > tcF + 1°K by powering off the circulation pump. Anti-freeze protection supersedes the minimum collector temperature limitation.

oEA Auxiliary heating option: In KLT23ST-PX and KLT33ST-PX

No: No auxiliary heating required, tEA is not accessed.

Yes: Auxiliary heating required according to temperature tEA.

tEA Auxiliary heating temperature: sd3 is used when parameter Pb3=Yes, or sd2 when Pb3=No as water storage tank probe. When the water storage tank probe (sd3 o sd2) < tEA, auxiliary heating is required. When the water storage tank probe (sd3 o sd2) > tEA+1°K, auxiliary heating is required.

odl Surplus energy use option: In KLT33ST-PX

No: No water storage tank power dissipated, tdl is not accessed.

Yes: Water storage tank power dissipated at temperature tdl..

tdl Surplus energy use temperature: sd3 is used when parameter Pb3=Yes, or sd2 when Pb3=No as water storage tank probe. When the water storage tank probe (sd3 o sd2) > tdl, the surplus power in the water storage tank is dissipated to an external system. When the water storage tank probe (sd3 o sd2) < tdl - 1°K, the surplus energy use function is powered off.

Pb3 Sd3 option (top probe): Indication to the thermostat whether there is a top probe (sd3) (Yes) or there is lack of it (No). The sd3 is used for auxiliary heating and surplus energy use. When no sd3 is available (Pb3=No), the thermostat uses sd2 for these functions.

uSd Probe to view: Selection of the probe to view

1: sd1, solar collector.

2: sd2, water storage tank bottom probe.

3: sd3, water storage tank top probe, only possible when Pb3=Yes.

Hn1 Manual/automatic circulation pump: Forcing of the

circulation pump status.

On: circulation pump always on

OFF: circulation pump always off

Aut: circulation pump according to the thermostat setting.

Hn2 Manual/automatic auxiliary heating: Forcing of the auxiliary

heating status. In KLT23ST-PX and KLT33ST-PX.

On: Auxiliary heating always on

OFF: auxiliary heating always off

Aut: auxiliary heating according to the thermostat setting.

Hn3 Manual/automatic surplus energy use: Forcing of the surplus energy use status. In KLT33ST-PX.

On: surplus energy use always on

OFF: surplus energy use always off

Aut: surplus energy use according to thermostat setting

H0 Configuration: See corresponding paragraph.

H5 Access code: See “Access to protected parameters”